

Small Type Tactile Switches STR Series

FEATURES

1. Ultra small size. (2.5×1.6mm)
2. Good feeling with the actuator.
3. High reliability with the small, thin, and dustproof design.
4. IPX8 water resistance.

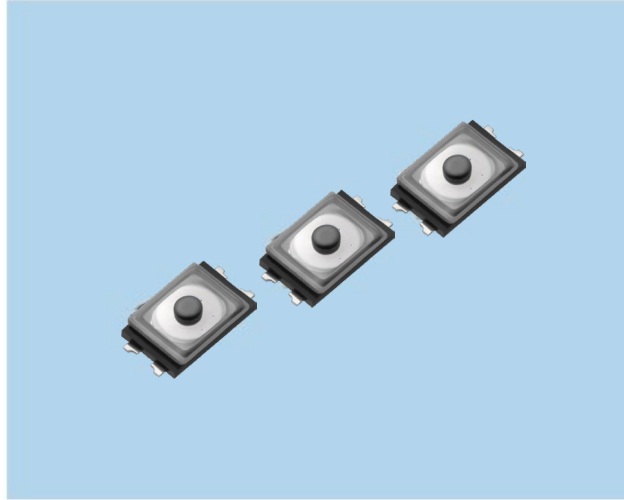

APPLICATIONS

Mobile Phones, Smartphones, Digital Cameras, Game Machines and etc.

MODEL NAME CODE

S T R - 055 A 16 AX

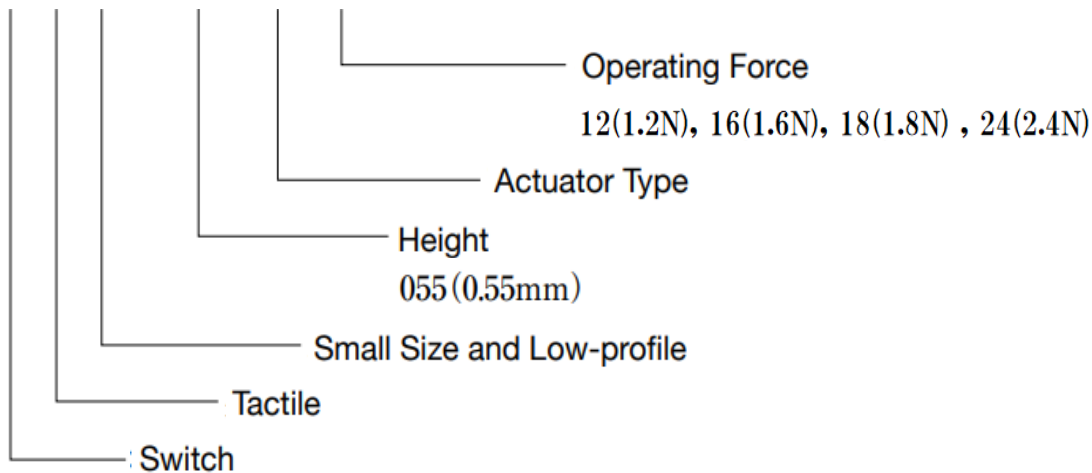

• Any products mentioned in this catalog are subject to any modification in their appearance and others for improvements without prior notification.
• The details listed here are not a guarantee of the individual products at the time of ordering. When using the products, you will be asked to check their specifications.

STR Series SPECIFICATIONS

Electrical Characteristics	Rating(Resistive load)	DC15V, 20mA
	Contact Resistance	1Ω or less
	Insulation Resistance	10MΩ or more
	Withstand Voltage	1 minute at AC 100V
Life	STR-055A12AX	500,000 times
	STR-055A16AX	500,000 times
	STR-055A18AX	500,000 times
	STR-055A24AX	200,000 times
Water Resistance	Protective resistance	IPX8

TYPE

Model Name Code	Model Name	Operating Force	Boss	Pcs/Reel
STR-055A12AX	R 668174	1.2N	Without	25,000
STR-055A16AX	R 668189	1.6N	Without	25,000
STR-055A18AX	R 668182	1.8N	Without	25,000
STR-055A24AX	R 668070	2.4N	Without	25,000

DIMENSIONS

