



VISION CP12170

12V17Ah

Specifications

Nominal Voltage		12V
Rated Capacity (20 hour rate)		17Ah
Dimensions	Total Height (with terminals)	6.57 inches (167mm)
	Height	6.57 inches (167mm)
	Length	7.13 inches (181mm)
	Width	3.03 inches (77mm)
Weight		Approx. 12.61lbs (5.7Kg)

Characteristics

Capacity*	20 hour rate (0.85A)	17Ah
	10 hour rate (1.6A)	16Ah
	5 hour rate (3A)	15Ah
	1 hour rate (12A)	12Ah
	15 minute Rate (36A)	9.00Ah
Internal Resistance	Full charged Battery 77°F(25°C)	16mΩ
Capacity affected by Temperature (20 hour rate)	104°F(40°C)	102%
	77°F(25°C)	100%
	32°F(0°C)	85%
	5°F(-15°C)	65%
Self-Discharge 68°F(20°C)	Capacity after 3 month storage	90%
	Capacity after 6 month storage	80%
	Capacity after 12 month storage	60%
Max. Discharge Current 77°F(25°C)	255A (5s)	
Terminal	F3/F4	
Charge (Constant Voltage)	Cycle	14.5-14.9V/77°F(25°C) Max. Current 6.8A
	Float	13.6-13.8V/77°F(25°C)

Constant power discharge ratings-watts per cell at 25°C(77°F)

End Point Volts/Cell	5min	10min	15min	30min	45min	1h	2h	3h	5h
1.60V	131	82.5	66.3	38.3	28.1	22.6	14.6	10.6	6.64
1.65V	126	80.0	64.0	37.2	27.1	21.7	13.7	9.94	6.64
1.70V	121	76.8	61.4	36.0	25.9	20.6	12.9	9.18	6.30
1.75V	114	73.4	58.9	34.6	24.7	19.5	12.1	8.37	5.95
1.80V	108	70.0	56.6	33.2	23.3	18.2	11.0	7.45	5.52

*The above data are average values, and can be obtained within 3 charge/discharge cycles. These are not minimum values.

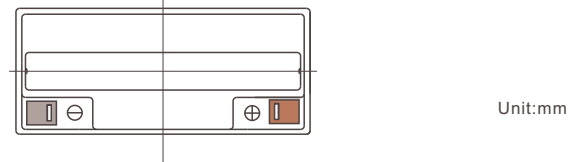
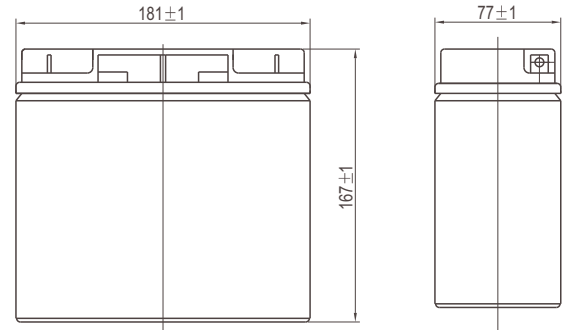

Unit:mm

Terminal

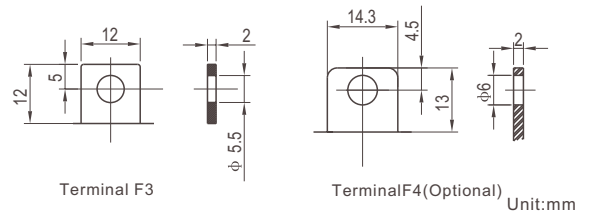

Unit:mm

Discharge current v's time 77°F(25°C)

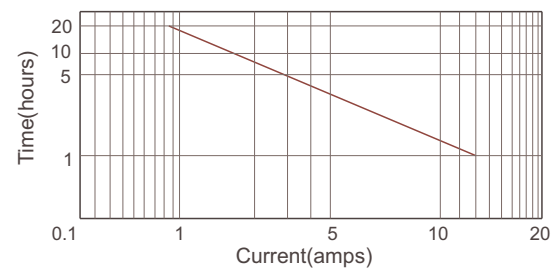

Discharge characteristic (25°C)

