

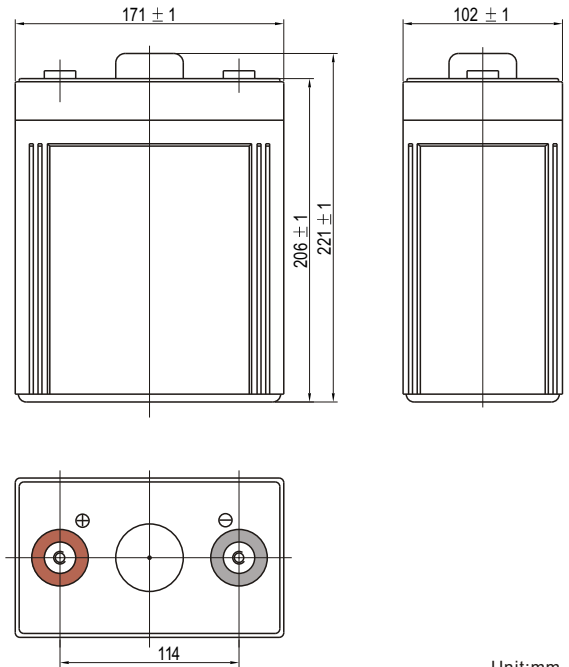

VISION **CL 150** 2V 150Ah

■ Specifications

Nominal Voltage		2V
Rated Capacity (10 hour rate)		150Ah
Dimensions	Total Height (with terminals)	8.70 inches (221mm)
	Height	8.11 inches (206mm)
	Length	6.73 inches (171mm)
	Width	4.02 inches (102mm)
Weight		Approx. 18.11lbs (8.2Kg)



Unit:mm

■ Characteristics

Capacity* 77°F(25°C)	10 hour rate (15A)	150Ah
	5 hour rate (27.2A)	136Ah
	1 hour rate (99.2A)	99.2Ah
	15 minute Rate (221A)	55.3Ah
Internal Resistance	Full charged Battery 77°F(25°C)	0.83mΩ
Capacity affected by Temperature (20 hour rate)	104°F(40°C)	102%
	77°F(25°C)	100%
	32°F(0°C)	85%
	5°F(-15°C)	65%
Self-Discharge 68°F(20°C)	Capacity after 3 month storage	90%
	Capacity after 6 month storage	80%
	Capacity after 12 month storage	60%
Max. Discharge Current 77°F(25°C)	750A (5s)	
Terminal	F10	
Charge (Constant Voltage)	Cycle	2.35-2.45V/77°F(25°C) Max. Current 30A
	Float	2.25-2.3V/77°F(25°C)

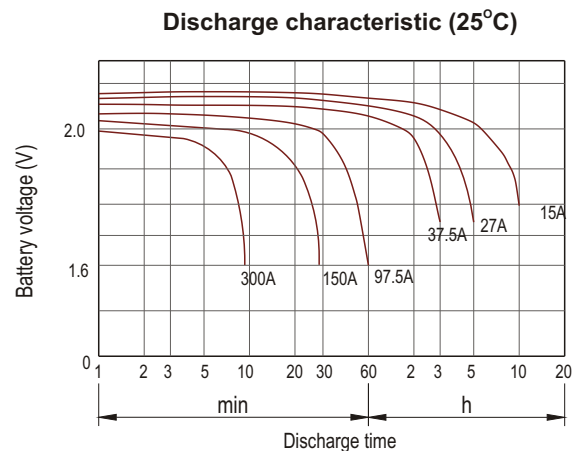
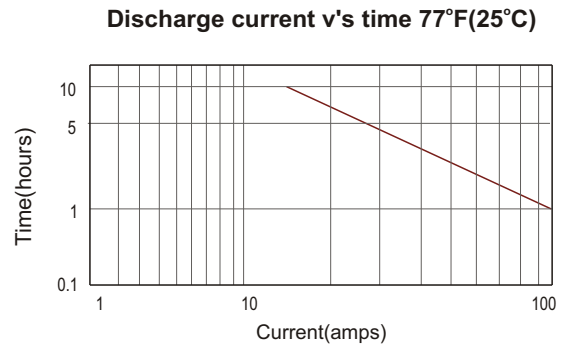

Constant power discharge ratings-watts per cell at 25°C(77°F)

End Point Volts/Cell	10min	15min	30min	45min	1h	2h	3h	5h
1.60V	426	386	294	221	184	118	79.8	58.5
1.65V	402	365	279	210	176	114	77.9	57.5
1.70V	377	344	264	200	168	110	75.8	56.3
1.75V	352	323	249	189	160	106	73.5	55.1
1.80V	327	301	233	178	151	101	71.0	53.8

*The above data are average values, and can be obtained within 3 charge/discharge cycles. These are not minimum values.